



RST 7700 RAINWATER STORAGE AND RE-USE SYSTEM TECHNICAL DRAWINGS

Adelaide +61 8 8212 9733	Brisbane +61 7 3368 3966	Darwin +61 1300 663 225	Hobart +61 1300 768 922	Melbourne +61 3 9646 3911
Perth +61 1300 794 654	Sydney +61 2 9669 6000	Townsville +61 7 4728 5711	Auckland +64 9 272 7010	Kuala Lumpur +60 3 7710 6514

Website: www.ecosol.com.au

Ecosol Pty Ltd ABN 86 059 012 243 Ecosol (NZ) Wastewater Filtration Systems Ltd (Reg. No AK/1172504)
Ecosol (UK) Wastewater Filtration Systems Ltd (Reg. No 4367214) Ecological Filtration Systems Sdn Bhd (Reg. No 651041-U)

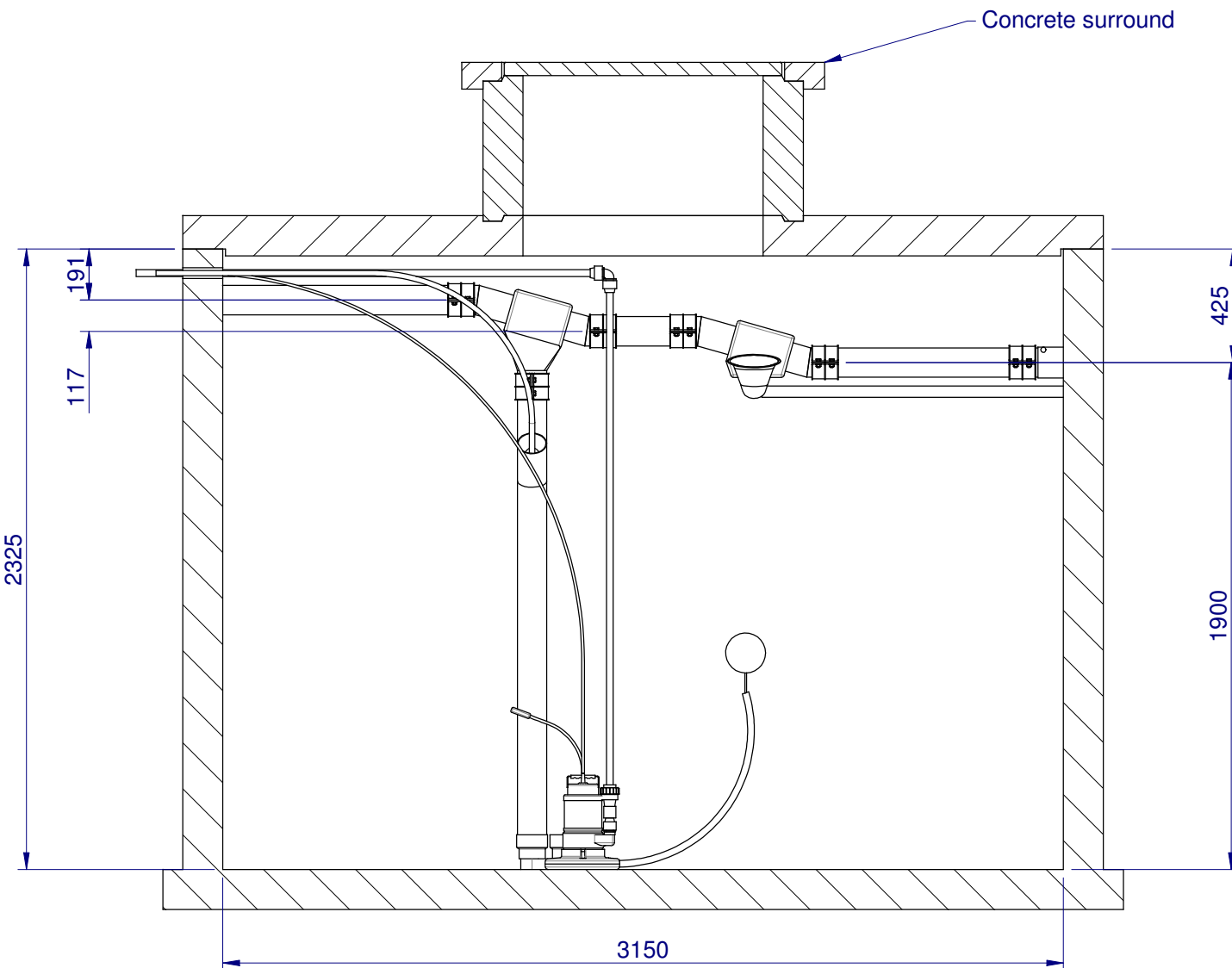
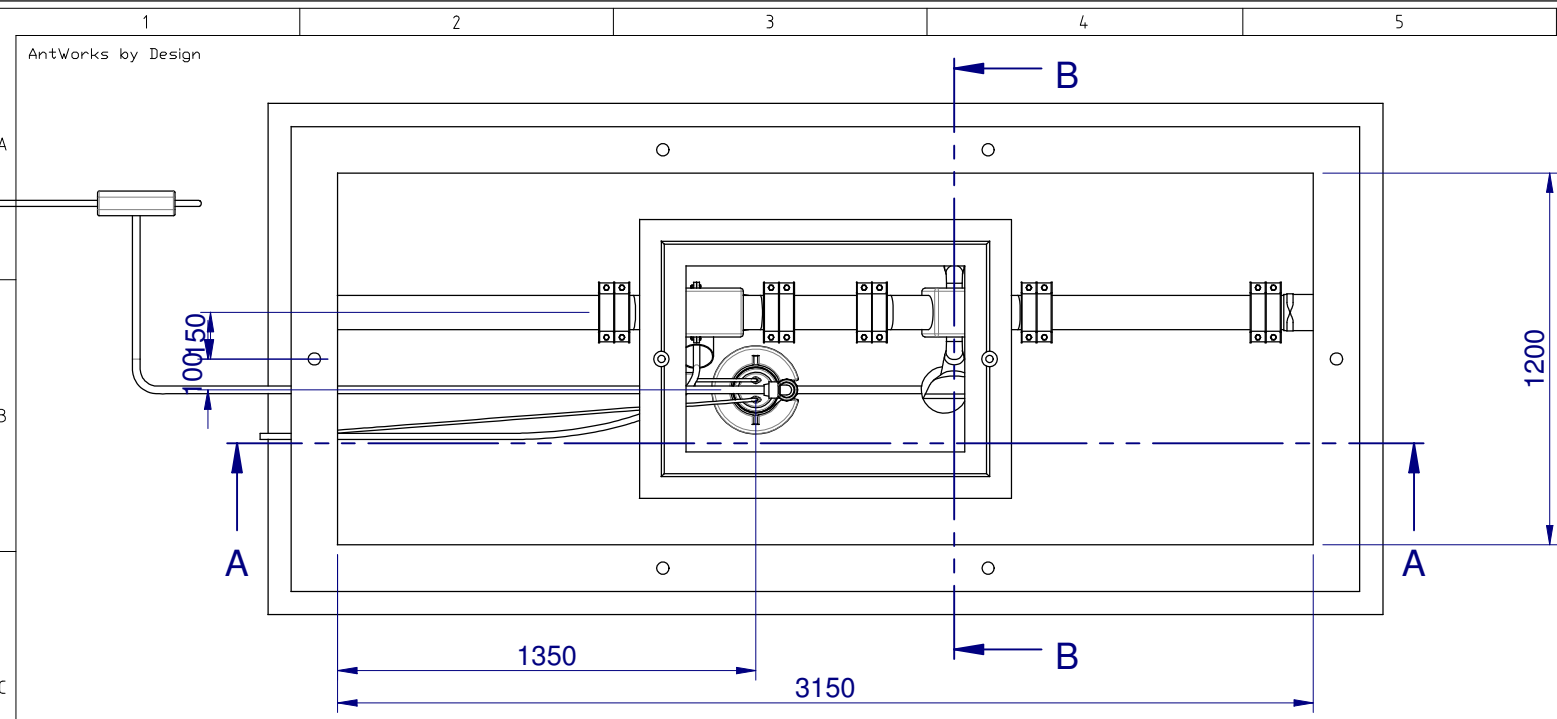

SECTION A-A

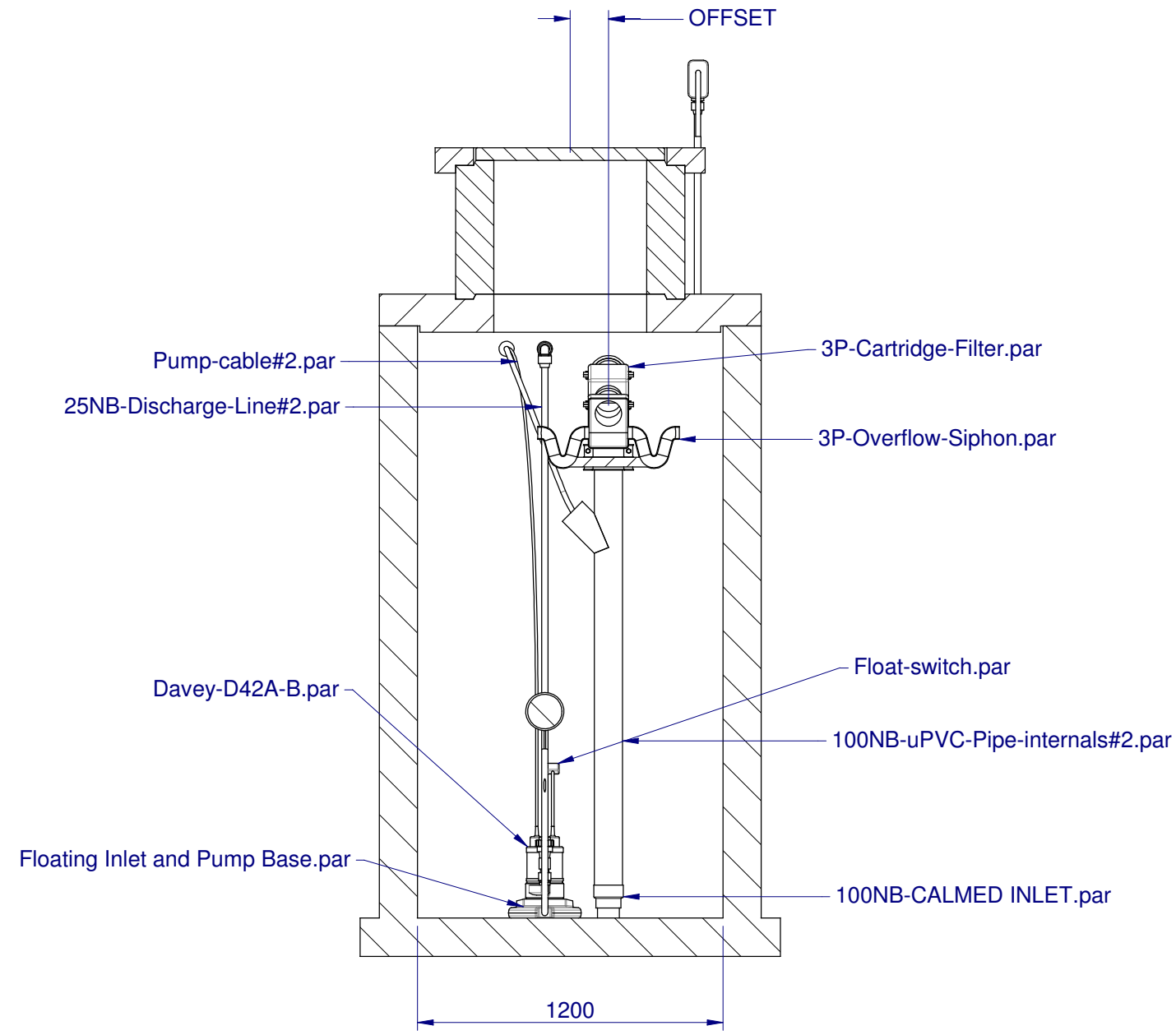

SECTION B-B

CAD FILE No. **RST-7700.DFT**

REV	DESCRIPTION	DRAWN	CHECK	APPROVED	DATE
D	REVISED SECTION B-B	Ant	D.B	A.M	13.02.08
C	REVISED COMPONENTS	Ant	D.B	A.M	20.08.07
B	REVISED OUTLET OFFSET	Ant	D.B	A.M	15.05.07
A	Original Issue	Ant	D.B	A.M	02.05.07

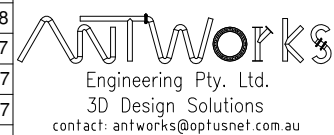

THIS DOCUMENT AND THE IDEAS AND DESIGNS HEREIN, AS AN INSTRUMENT OF PROFESSIONAL SERVICE IS THE PROPERTY OF ECOSOL Pty. Ltd. AND IS NOT TO BE USED IN WHOLE OR IN PART WITHOUT THE WRITTEN AUTHORISATION OF ECOSOL Pty. Ltd.

DRAWN	DATE:	DESIGN CHECK	DATE:	PROJECT No:
Ant	2 MAY 07		2 MAY 07	
DRAWING CHECK	DATE:	PROJ. MANAGER	DATE:	CONTRACT No:
A.M	2 MAY 07		2 MAY 07	
DESIGN ENG.	DATE:			CAD FILE No:
	2 MAY 07			



TITLE: **RAINWATER STORAGE TANK**
UNIT SIZE : RST 7700

DRAWING No.	REV
RST 7700	D
SHEET 1 OF 2	
SCALE: Noted	A1

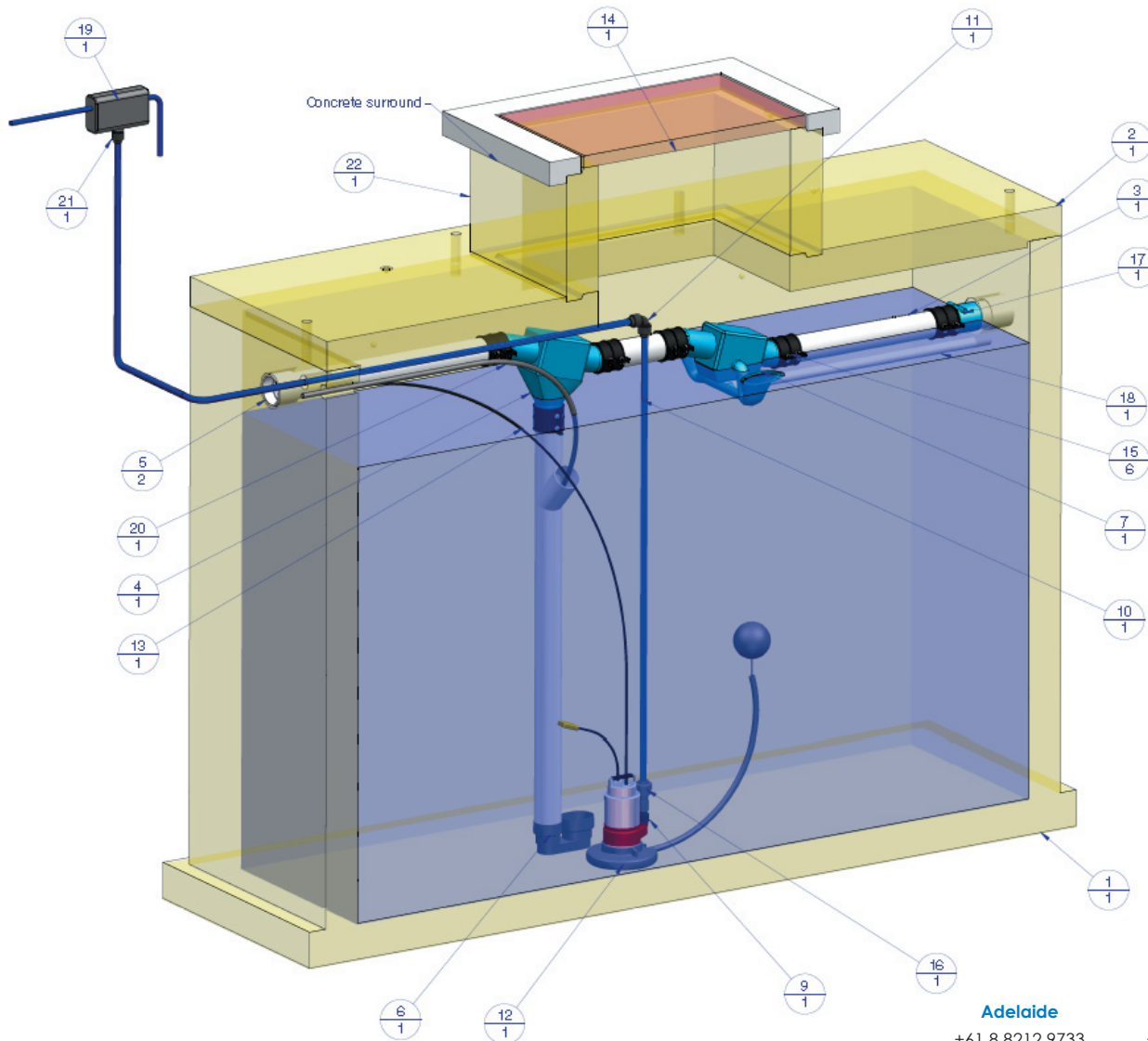

Ecosol RST 7700 Rainwater Storage and Re-use System

Item	Description	Material	Qty
1	Ecosol Rainwater Storage Tank 7,000 litres	Concrete	1
2	Ecosol Rainwater Storage Tank cover slab details	Concrete	1
3	110 sewer pipe uPVC	PVC	1
4	3P cartridge filter PF	LDPE	1
5	100NB uPVC socket coupling PN18	PVC	2
6*	110 dia calmed inlet	PVC	1
7	3P duo overflow	LDPE	1
8*	Submersible pump, 240 VAC c/w float switch and cable	Pump	1
9*	25mm x 1" male iron adapter plasson	Polypropylene, general purpose	1
10	25mm poly pipe, MDPE PN12.5	Polyethylene, low density	1
11	25mm, 90 degree elbow plasson	Polypropylene, general purpose	1
12*	Davey floating inlet and pump base	Polyethylene, low density	1
13	240 vac pump power supply cable	Brief material specification	1
14	Access cover	Iron, grey cast type 20	1
15	110 Pipe coupling		6
16*	25NB ball check valve, single union	Polyethylene, low density	1
17	3P backflow prevention valve	PVC	1
18*	32NB uPVC pipe, support bar	PVC	1
19	Team Poly rain bank controller	Brief material specification	1
20	20NB water flush line for 3P filter	Polypropylene, general purpose	1
21	25mm x 3/4" male iron adapter plasson	Polypropylene, general purpose	1
22	Access riser	Concrete	1

Adelaide
+61 8 8212 9733

Brisbane
+61 7 3368 3966

Darwin
+61 1300 663 225

Hobart
+61 1300 768 922

Melbourne
+61 3 9646 3911

Perth
+61 1300 794 654

Sydney
+61 2 9669 6000

Townsville
+61 7 4728 5711

Auckland
+64 9 272 7010

Kuala Lumpur
+60 3 7710 6514

Website: www.ecosol.com.au

Ecosol Pty Ltd ABN 86 059 012 243 Ecosol (NZ) Wastewater Filtration Systems Ltd (Reg. No AK/1172504)
Ecosol (UK) Wastewater Filtration Systems Ltd (Reg. No 4367214) Ecological Filtration Systems Sdn Bhd (Reg. No 651041-U)