



# RST 72500 RAINWATER STORAGE AND RE-USE SYSTEM TECHNICAL DRAWINGS

<b>Adelaide</b> +61 8 8212 9733	<b>Brisbane</b> +61 7 3368 3966	<b>Darwin</b> +61 1300 663 225	<b>Hobart</b> +61 1300 768 922	<b>Melbourne</b> +61 3 9646 3911
<b>Perth</b> +61 1300 794 654	<b>Sydney</b> +61 2 9669 6000	<b>Townsville</b> +61 7 4728 5711	<b>Auckland</b> +64 9 272 7010	<b>Kuala Lumpur</b> +60 3 7710 6514

Website: [www.ecosol.com.au](http://www.ecosol.com.au)

Ecosol Pty Ltd ABN 86 059 012 243 Ecosol (NZ) Wastewater Filtration Systems Ltd (Reg. No AK/1172504)  
Ecosol (UK) Wastewater Filtration Systems Ltd (Reg. No 4367214) Ecological Filtration Systems Sdn Bhd (Reg. No 651041-U)

AntWorks by Design

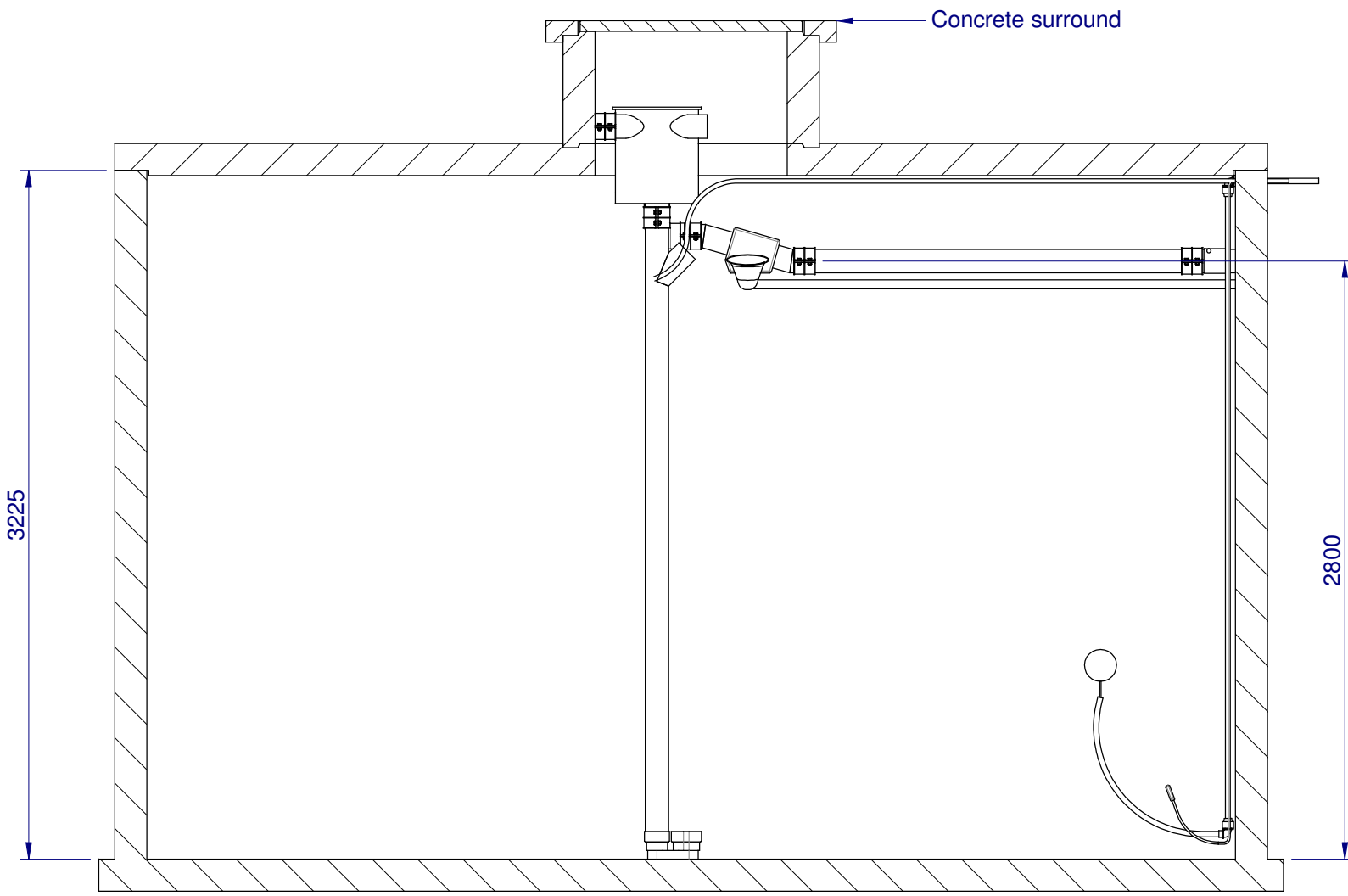
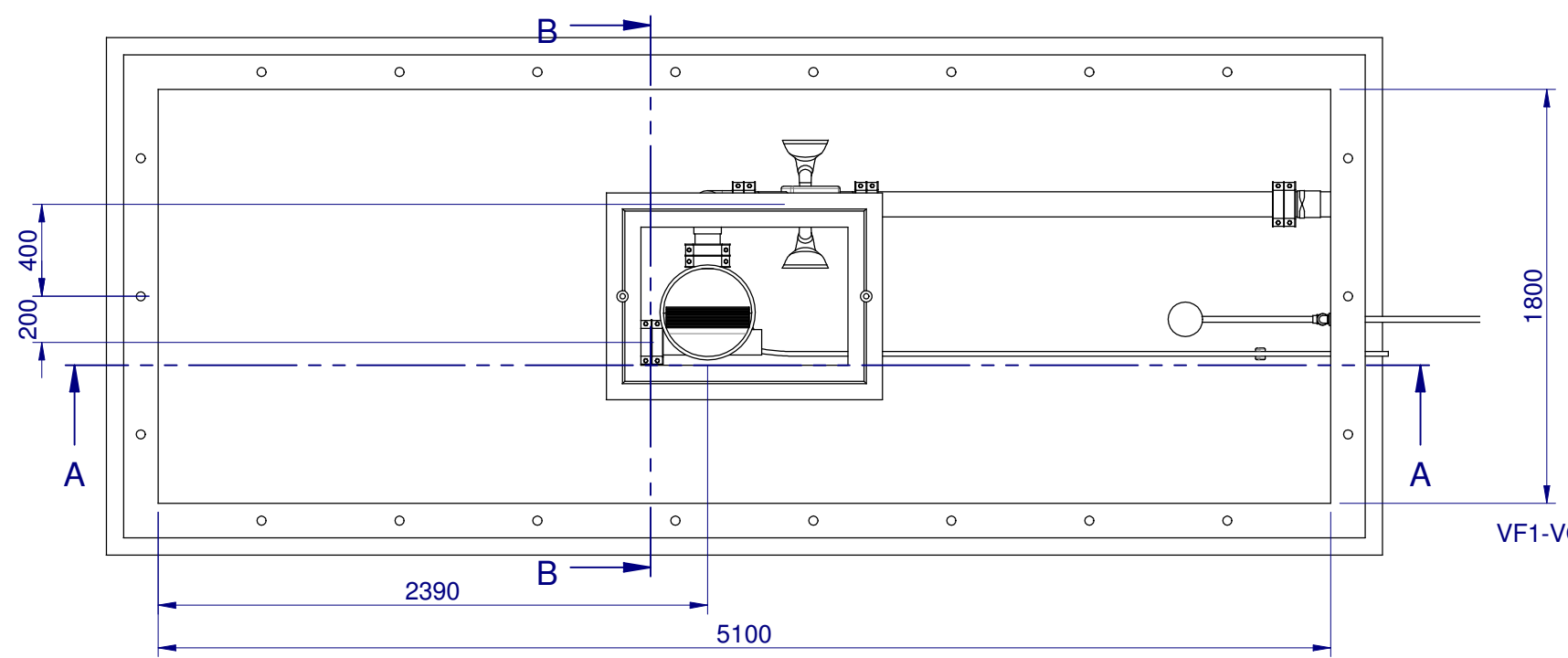

SECTION A-A

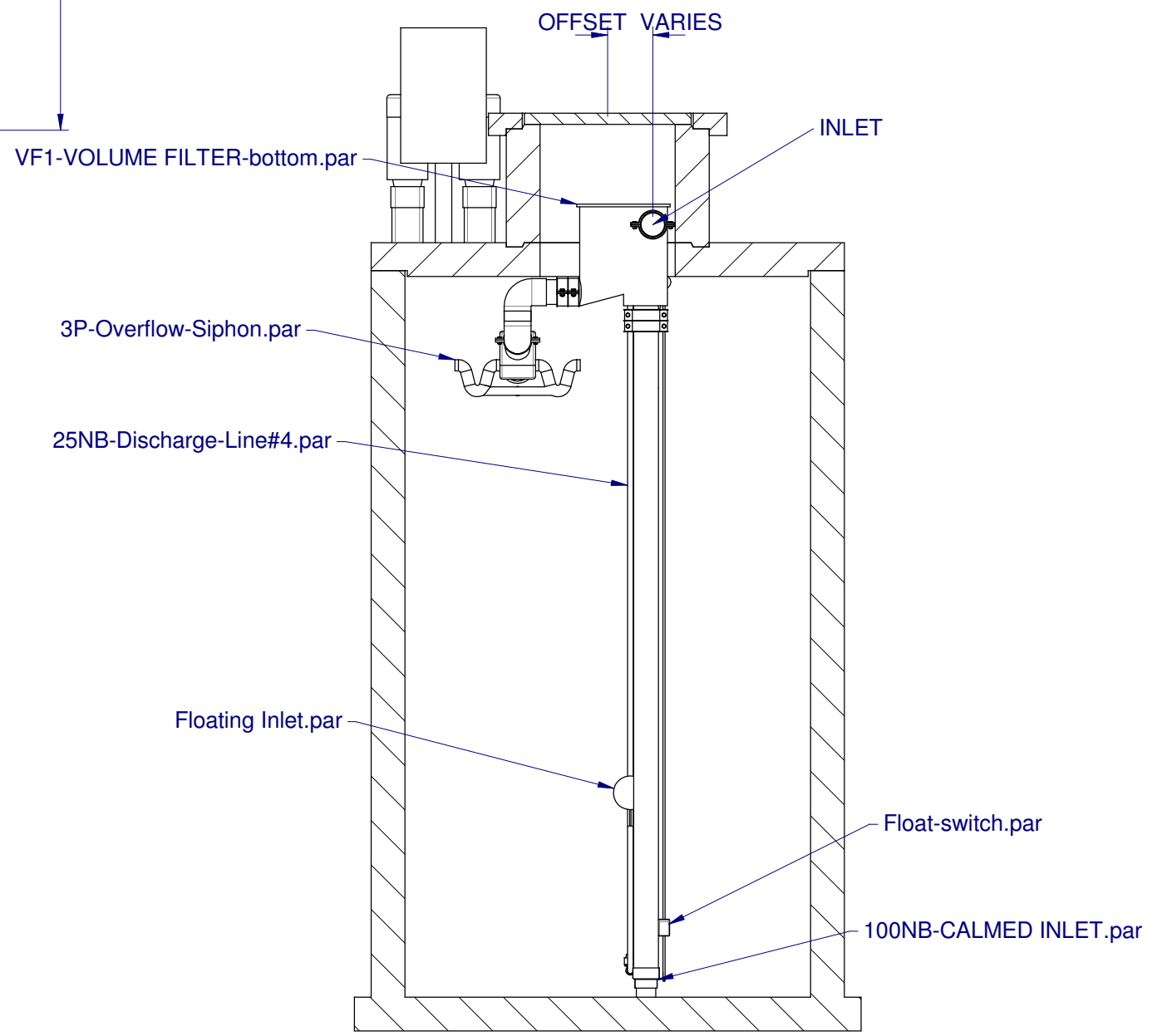

SECTION B-B

REV	DESCRIPTION	DRAWN	CHECK	APPROVED	DATE
E	REVISED SECTIONS A-A & B-B	Ant	D.B	A.M	13.02.08
D	REVISED COMPONENTS	Ant	D.B	A.M	21.08.07
C	REVISED INLET POSITION	Ant	D.B	A.M	17.05.07
B	REVISED INLET FILTER	Ant	D.B	A.M	15.05.07
A	Original Issue	Ant	D.B	A.M	02.05.07

**ANTWORKS**  
Engineering Pty. Ltd.  
3D Design Solutions  
contact: antworks@optusnet.com.au

THIS DOCUMENT AND THE IDEAS AND DESIGNS HEREIN, AS AN INSTRUMENT OF PROFESSIONAL SERVICE IS THE PROPERTY OF ECOSOL Pty. Ltd. AND IS NOT TO BE USED IN WHOLE OR IN PART WITHOUT THE WRITTEN AUTHORIZATION OF ECOSOL Pty. Ltd.

DRAWN	DATE:	DESIGN CHECK	DATE:	PROJECT No:
Ant	2 MAY 07		2 MAY 07	
DRAWING CHECK	DATE:	PROJ. MANAGER	DATE:	CONTRACT No:
A.M	2 MAY 07		2 MAY 07	
DESIGN ENG.	DATE:			CAD FILE No:
	2 MAY 07			

**Ecosol**  
WASTEWATER FILTRATION SYSTEMS  
contact: info@ecosol.com.au  
website: www.ecosol.com.au

CAD FILE No. **RST-72500.DFT**  
TITLE: **RAINWATER STORAGE TANK**  
**UNIT SIZE : RST 72500**

DRAWING No.	REV
<b>RST72500</b>	<b>E</b>
SHEET 1 OF 2	
SCALE: Noted	A1

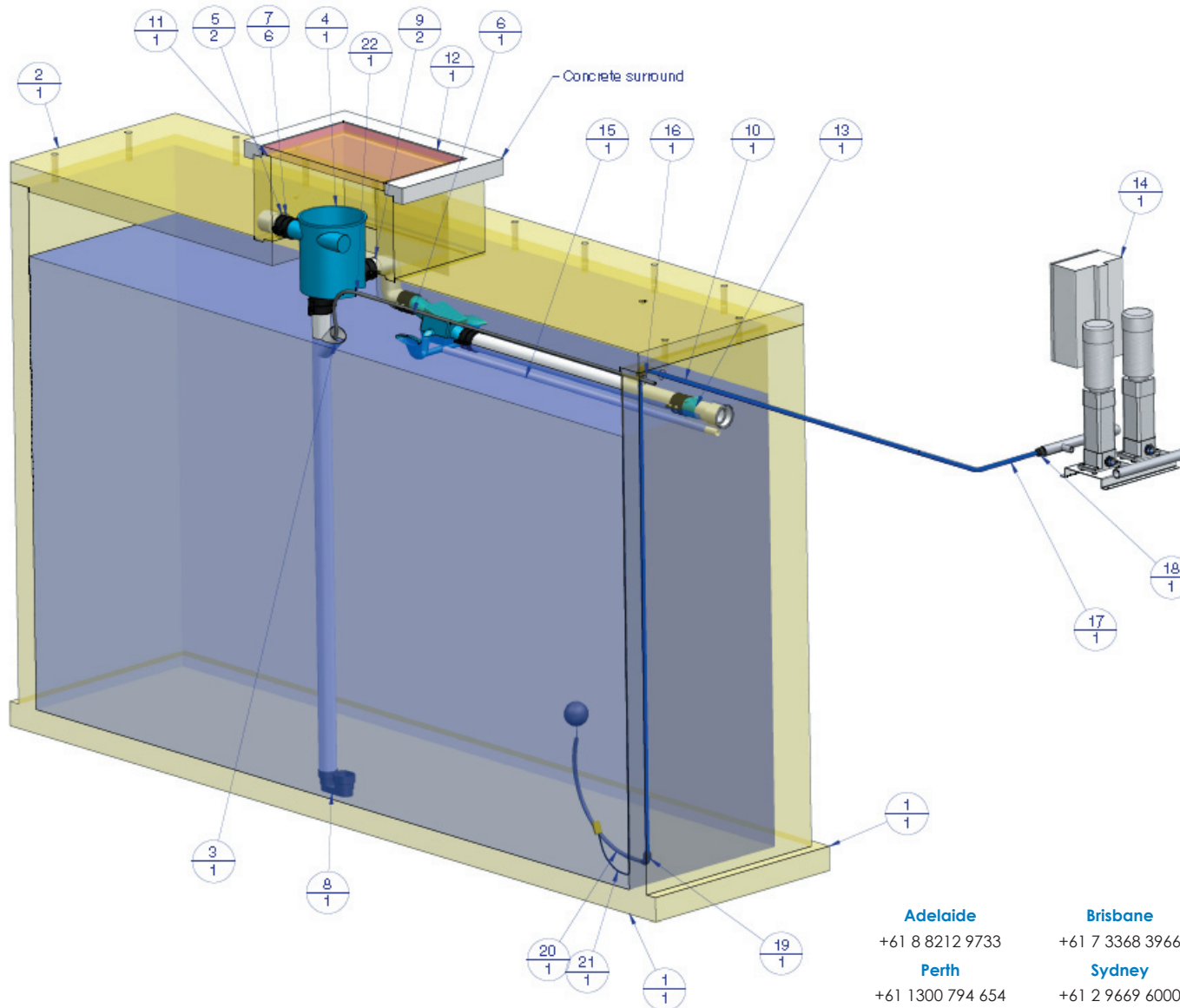

### Ecosol RST 72500 Rainwater Storage and Re-use System

Item	Description	Material	Qty
1	Ecosol Rainwater Storage Tank 25,000 litres	Concrete	1
2	Ecosol Rainwater Storage Tank cover slab details	Concrete	1
3	100 pipe PVC	PVC	1
4	3P Technik, VF1 volume filter	Brief material Specification	1
5	100NB uPVC socket coupling PN18	PVC	2
6	3P duo overflow	LDPE	1
7	110 pipe coupling		6
8*	110 dia calmed inlet	PVC	1
9	110NB 90 deg elbow	PVC	2
10	25mm poly pipe, MDPE PN12.5	Polyethylene, low density	1
11	Access riser	Concrete	1
12	Access cover	Iron, grey cast type 20	1
13*	3P backflow prevention valve	PVC	1
14	2" VDF rainbank pump set		1
15*	32NB u PVC pipe, support bar	PVC	1
16*	25mm, 90 degree elbow plasson	Polypropylene, general purpose	1
17	25mm Poly pipe, MDPE PN12.5	Polyethylene, low density	1
18	25mm x 1" male iron adapter plasson	Polypropylene, general purpose	1
19*	25mm x 1", 90 degree male iron elbow plasson	Polypropylene, general purpose	1
20*	Davey floating inlet	Polyethylene, low density	1
21*	Float switch	Brief material specification	1
22	20NB water flush line for 3P filter	Polypropylene, general purpose	1

**Adelaide**

+61 8 8212 9733

**Perth**

+61 1300 794 654

**Brisbane**

+61 7 3368 3966

**Sydney**

+61 2 9669 6000

**Darwin**

+61 1300 663 225

**Townsville**

+61 7 4728 5711

**Hobart**

+61 1300 768 922

**Auckland**

+64 9 272 7010

**Melbourne**

+61 3 9646 3911

**Kuala Lumpur**

+60 3 7710 6514

Website: [www.ecosol.com.au](http://www.ecosol.com.au)

Ecosol Pty Ltd ABN 86 059 012 243 Ecosol (NZ) Wastewater Filtration Systems Ltd (Reg. No AK/1172504)  
Ecosol (UK) Wastewater Filtration Systems Ltd (Reg. No 4367214) Ecological Filtration Systems Sdn Bhd (Reg. No 651041-U)